



CONERGY

Standalone inverters | Technical data

Conergy ISA 3000/5000 backup

Conergy ISA backup standalone inverters guarantee uninterrupted electrical power supply by using renewable energy – even if there are power cuts or fluctuations. When this emergency supply is not required, Conergy ISA backup inverters feed AC power into the public grid for a remuneration. All Conergy ISA backup inverters have an internal

MPPT (Maximum Power Point Tracking) charge controller. This controls the charging and power management and provides up to 20 % more energy output. Many years of international experience and innovative system enhancements ensure that Conergy ISA backup inverters are world leaders concerning system efficiency, reliability and service.



Maximum system efficiency with MPPT

Conergy ISA backup inverters use charge controllers with processor-controlled MPPT, which normally only is a standard for grid-connected inverters. This technology provides the battery always with the maximum power available. The integrated DC/DC regulator charges the battery at its voltage level. This faster, optimised battery charging supplies up to 20 % more energy.

Battery and power management

Conergy ISA backup inverters control the entire battery and power management. The battery's state of charge is constantly monitored by a current-compensating voltage meter. This meter can also compensate drops in the battery's state of charge due to temperature fluctuations. If there is a power failure, the power supply is maintained without interruptions via battery and inverter.

Robust and reliable

The components used in Conergy ISA backup inverters are designed for maximum reliability in order to easily withstand continuous heavy loads over many years. This is indicated by:

- | Electrolytic capacitors with a service life of up to 30,000 hours under full load
- | Output stages with five-fold voltage resistance
- | An operating temperature range between 0 and +60 °C
- | High-quality ball-bearing fans

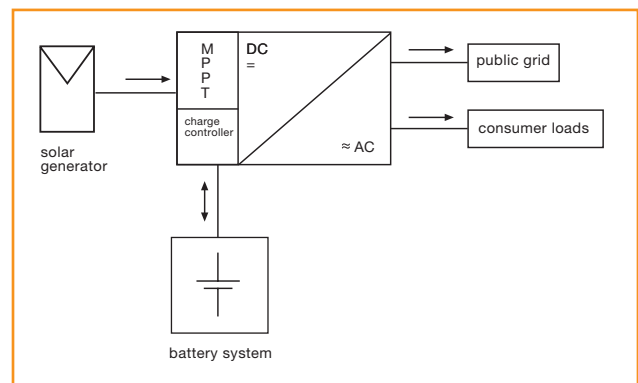

PHOTOVOLTAICS



CONERGY

Standalone inverters | Technical data

Conergy ISA 3000/5000 backup

	Conergy ISA 3000 backup	Conergy ISA 5000 backup
Solar generator		
Solar generator power (25 °C)	3,900 Wp	6,500 Wp
DC input power (40 °C)	3,400 W	5,500 W
Operation mode	MPP tracking (microprocessor)	MPP tracking (microprocessor)
Solar generator voltage range (V _{pmin} –V _{ocmax})	58–150 V _{oc}	145–350 V _{oc}
DC voltage ripple	< 5 % ss	< 5 % ss
Ground fault monitoring	Yes	Yes
Battery (Pb) 25 °C		
Battery configuration (cells in series)	24	60
Battery voltage (rated)	48 V	120 V
Inverter switch-on voltage	50 V	125 V
Inverter turn-off voltage	44 V	111 V
Gassing voltage	58 V	145 V
Trickle charge voltage	56 V	140 V
Overvoltage threshold	62 V	155 V
Temperature sensor		For charge threshold compensation (-0,003 V/°C per cell)
Charge control	I/U	I/U
Charge controller efficiency	94–98 % (10–100 % solar generator power)	94–98 % (10–100 % solar generator power)
Grid-connected mode		
Continuous output power 40 °C	3,000 VA	5,000 VA
Voltage/frequency range	197–253 V _{ac} /49,8–50,2 Hz	197–253 V _{ac} /49,8–50,2 Hz
Distortion factor	< 3 %	< 3 %
Power factor Cos Phi	1 (at nominal power)	1 (at nominal power)
Decoupling solar generator/grid	Highly insulating transformer	Highly insulating transformer
Off-grid mode		
Output voltage	230 V _{ac}	230 V _{ac}
Output frequency	50 Hz (true sinewave)	50 Hz (true sinewave)
Inverter efficiency	90-92 % (15-100 % output power)	90-92 % (15-100 % output power)
Continuous output power 40 °C	3,000 VA	5,000 VA
Continuous output power 50 °C	2,000 VA	3,300 VA
Peak output power 40 °C (10 sec)	4,500 VA	7,500 VA
Peak output power 50 °C (10 sec)	3,000 VA	5,000 VA
Power factor Cos Phi	0–1 (load-dependent)	0–1 (load-dependent)
General data		
Fuses	Solar generator (against reverse current), battery, grid, load	
Surge voltage protection (varistors and spark gaps)	Solar generator, battery	Solar generator, battery
Safety features	Short-circuit proof, protection class 1	Short-circuit proof, protection class 1
Standards	EN 61000-6-1: 2001, EN 61000-6-2: 2001, 61000-6-3: 2001 + A11: 2004 EN 61000-6-4: 2001, EN 61000-3-2: 2000, EN 50178: 1997, VDEW Standard for grid connection	
Ambient temperature range	0–40 °C/40–60 °C with derating	0–40 °C/40–60 °C with derating
Humidity	0–95 % non-condensing	0–95 % non-condensing
Protection type	IP 20	IP 20
Dimensions (W x H x D)	354 x 587 x 657 mm	354 x 587 x 657 mm
Weight	Approx. 65 kg	Approx. 85 kg
Housing	Floor-mounted	Floor-mounted

Available from: