



Omega

Flexible ground mount system

The Omega was specially designed for use in photovoltaic systems in open areas. Framed and unframed modules can be arranged in various configurations up to a surface of 45 m².

Ecological and functional

The 0.8 m¹ minimum module elevation above the ground prevents desolation and allows a secondary use of the terrain as pasture land. At the same time, the elevation prevents the modules from being shadowed by plants or snow.

Significant savings

The components of the Omega are pre-fitted according to the chosen module type and configuration. All connecting points of the intelligent structure have been specifically designed to facilitate installation. Innovative module support rails further reduce time and cost. All in all, this guarantees record-time installation.

Static reliability

Mounting Systems' service includes a static verification of all Omega configurations offered. On demand², an official assessible static calculation is available.

Maximum service life

All components are made of aluminium and stainless steel. This choice of material guarantees both full recyclability and a maximum service life due to high resistance to corrosion.



Open terrain



Unframed module



Framed module



Orientation
portrait



Orientation
landscape



¹ Other on request

² At extra cost.



Application	<i>Open terrain - ground mount</i>
Permissible charges	2200 PA ¹
PV modules	<i>Framed, unframed</i>
Module layout	<i>Aprox. 45 m²; standard: 3 rows in portrait orientation, the number of modules per row depending on the type of module²</i>
Module orientation	<i>Landscape, portrait</i>
Module inclination	15° - 35° ³
Size of the module array	<i>Aprox. 45 m²⁴</i>
Ground clearance	<i>Aprox. 0.8 m²</i>
Standards	<i>Eurocode 1 - Actions on structures Eurocode 9 - Design of aluminium structures⁵</i>
Support profiles	<i>Extruded Aluminium (EN AW 6060 T6), (EN AW 6063 T66)</i>
Small parts	<i>Stainless steel (V2A)</i>
Colour	<i>Natural</i>
Warranty	10 years ⁶

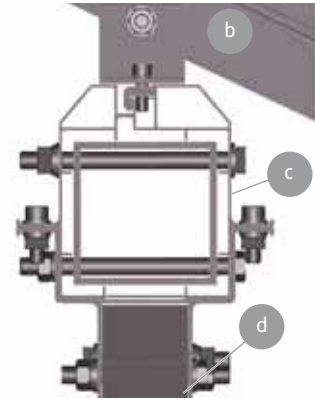

Detail cross beam

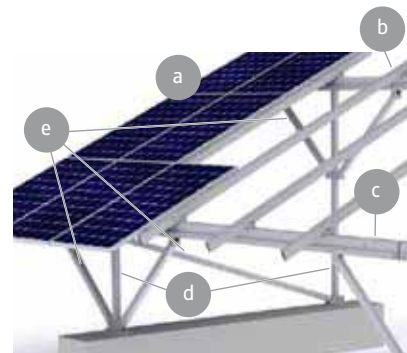

- a** PV module
- b** Module support profile
- c** Cross beam with joiner piece
- d** Legs
- e** Struts

1 For a module surface of 40 m²; higher loads on demand.
2 Within the limitations of the maximum surface allowable and the specific module size, various configurations are possible.
3 Other on request.
4 Bigger on demand.
5 Official assesible static calculation available on request, at extra cost.
6 Please find the exact terms in the Mounting Systems GmbH Warranty document.